

Dormitor VALY

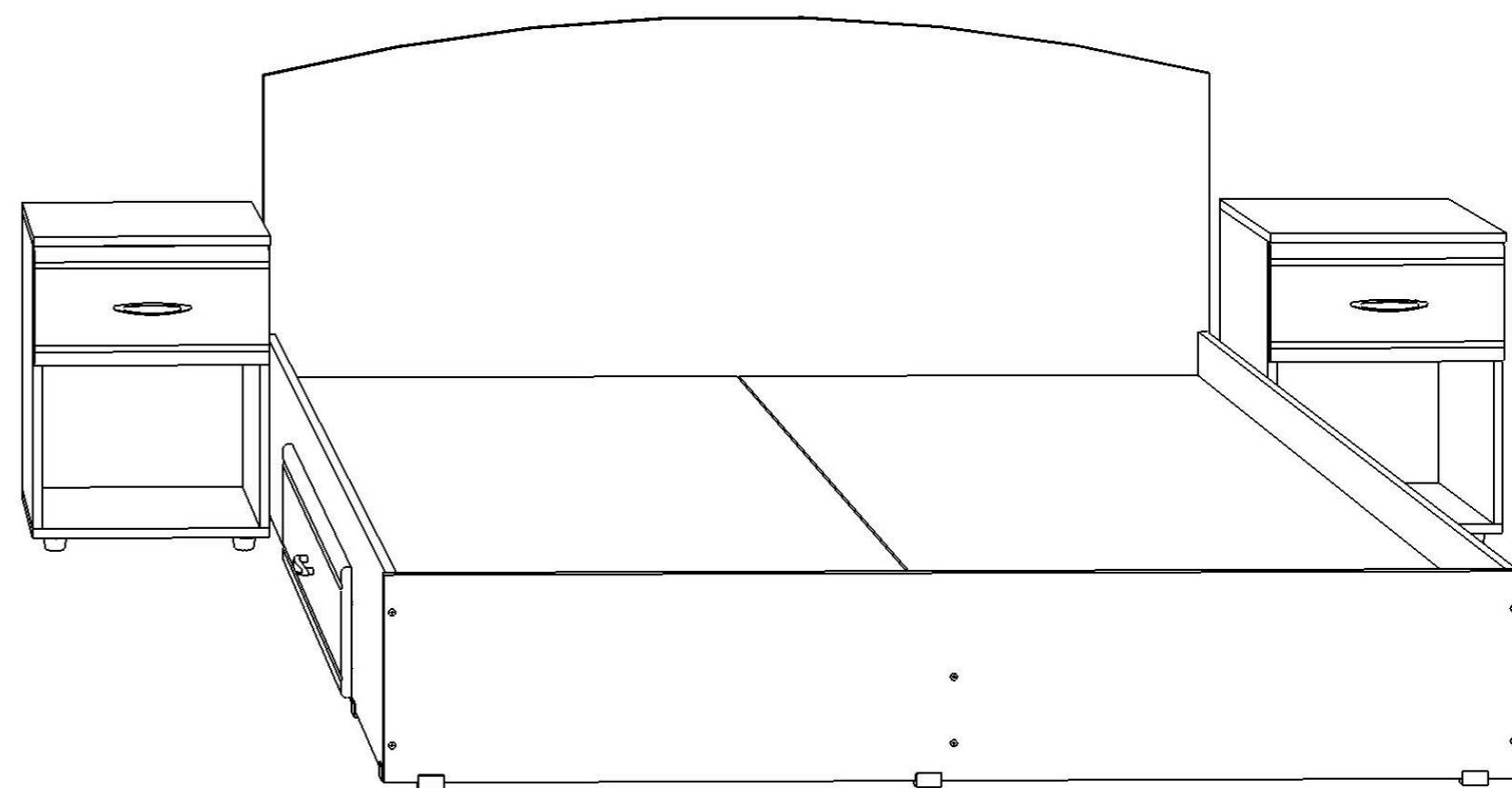

Dormitor VALY - Schita Montaj

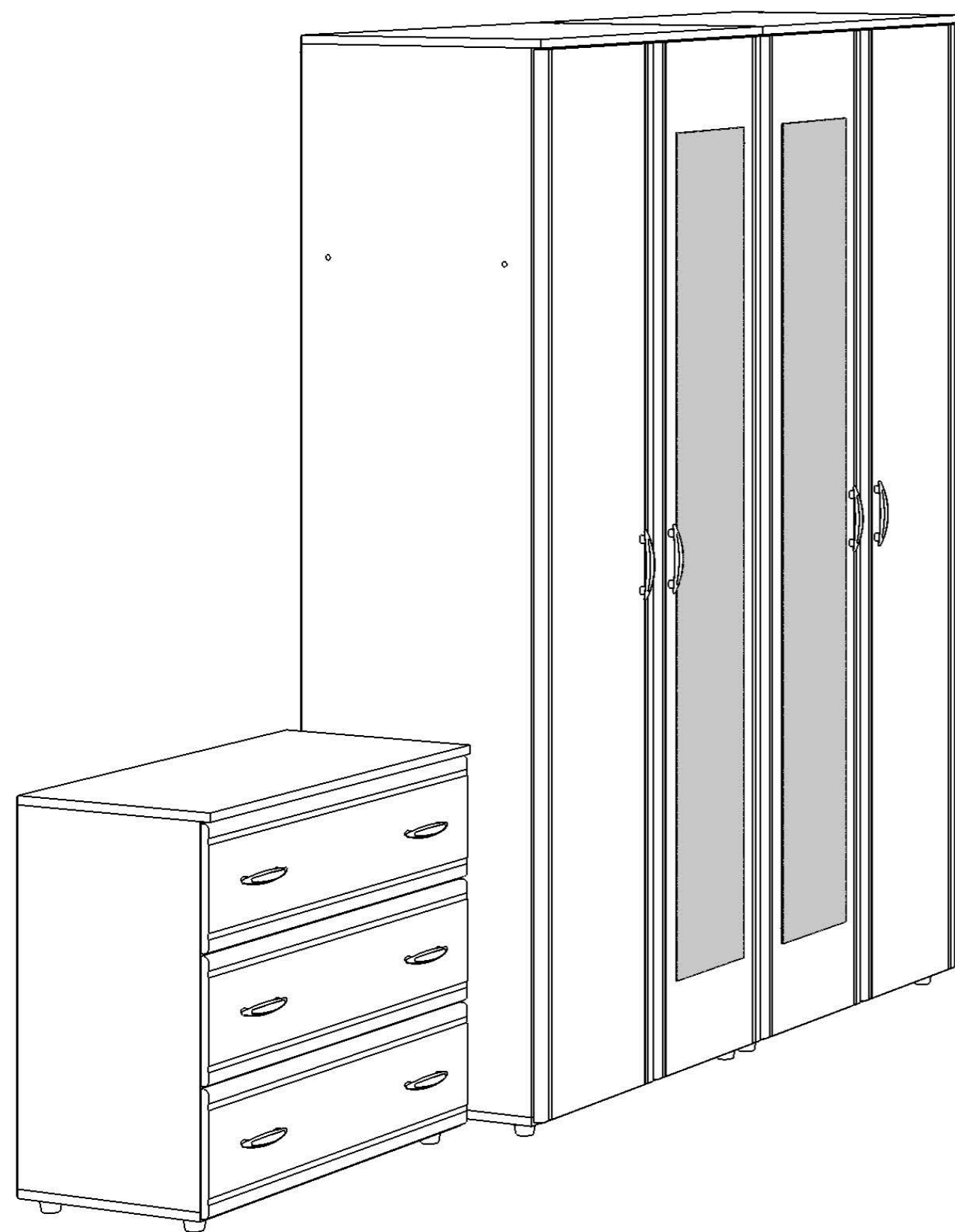
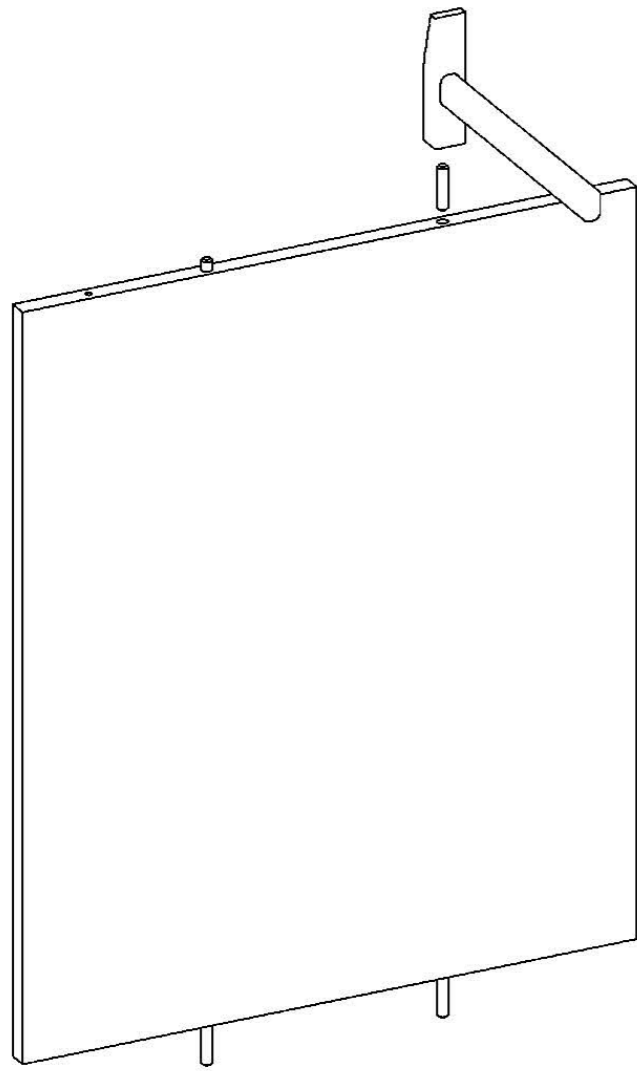

Fig. 1

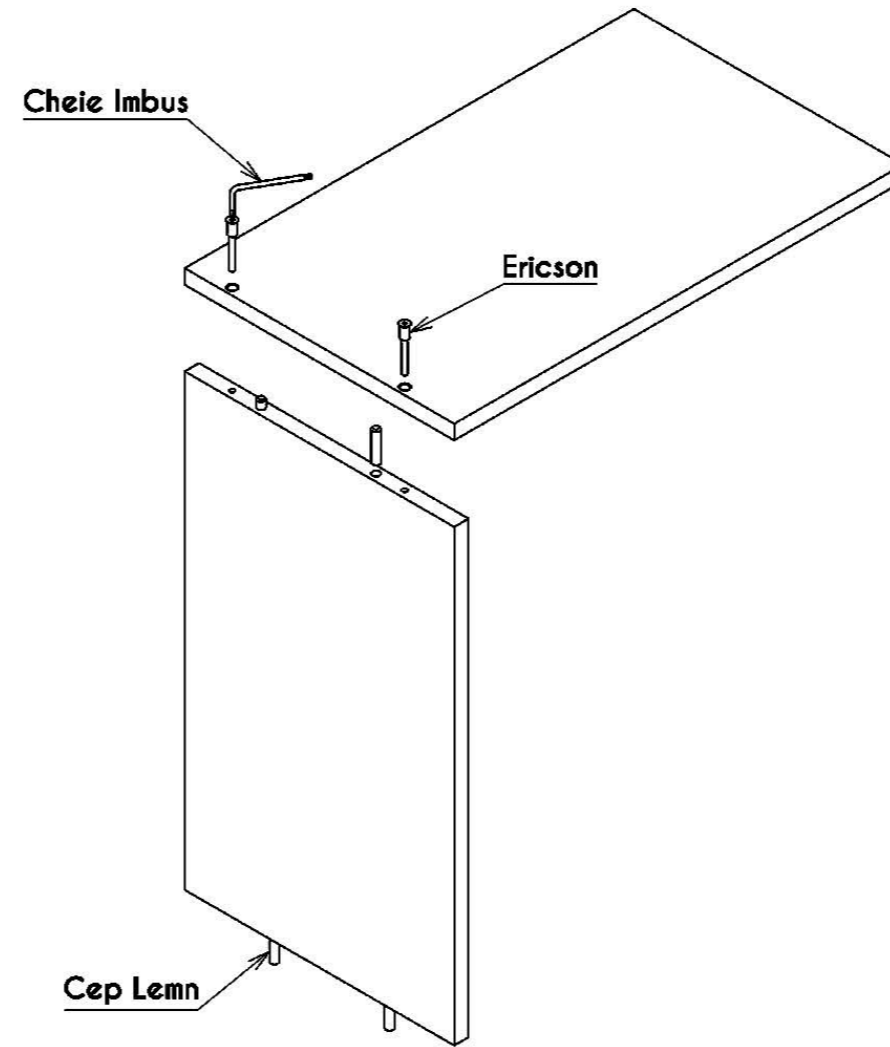

Fig. 2

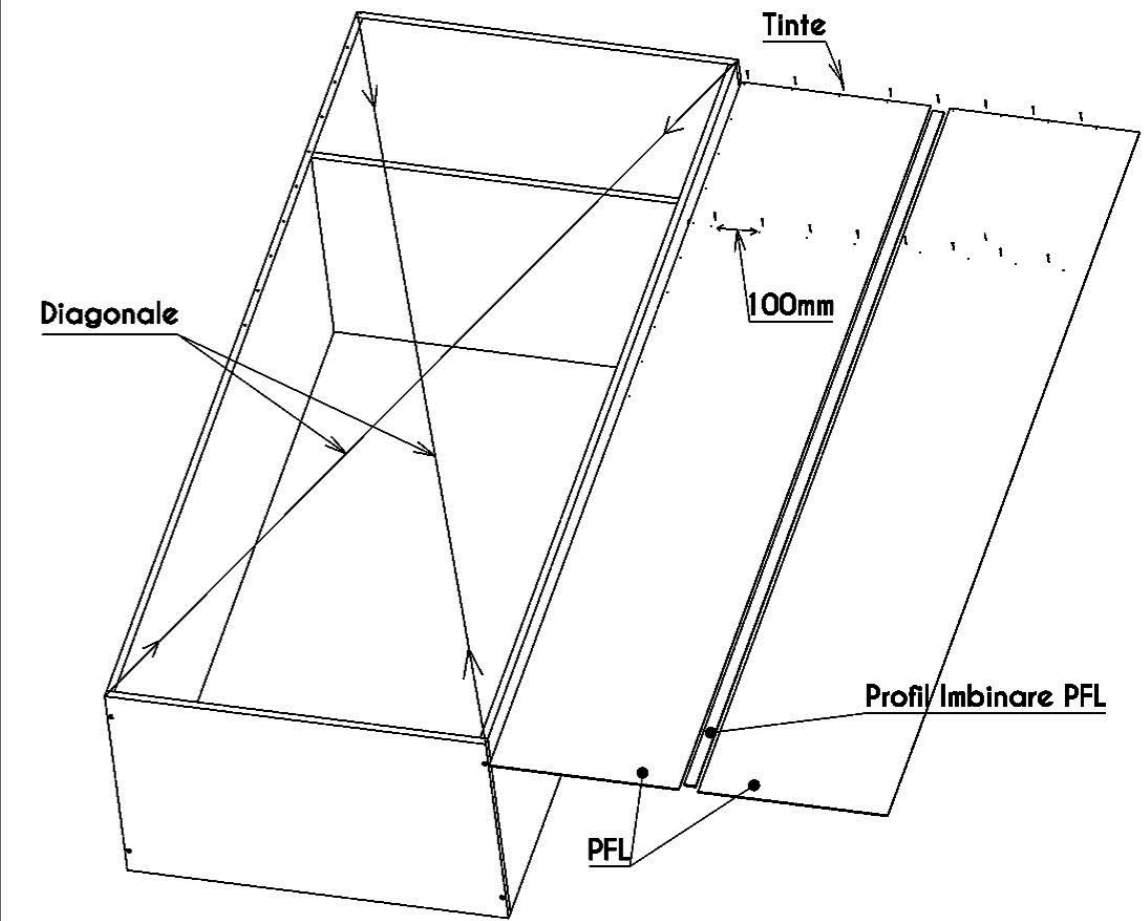

Fig. 3

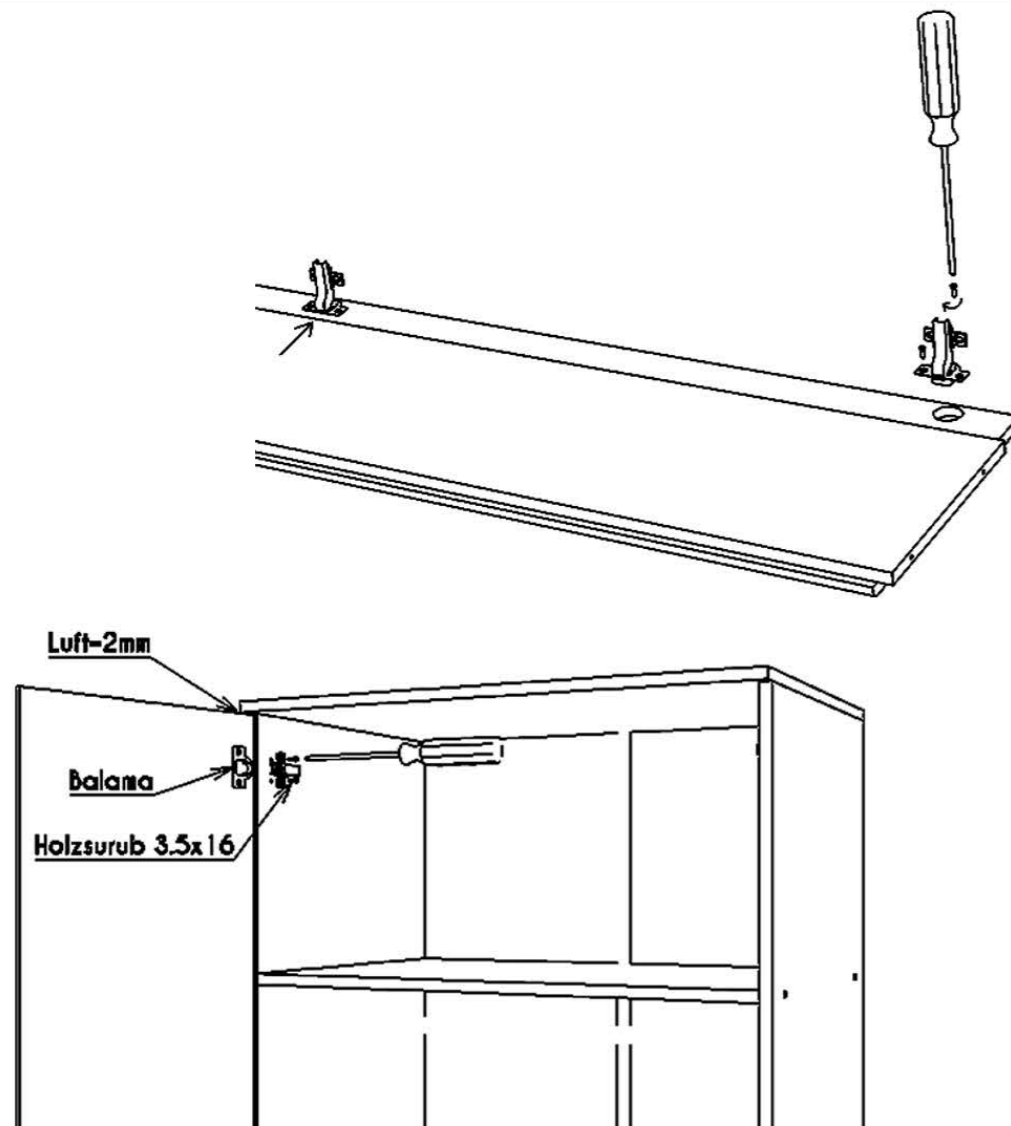

Fig. 4

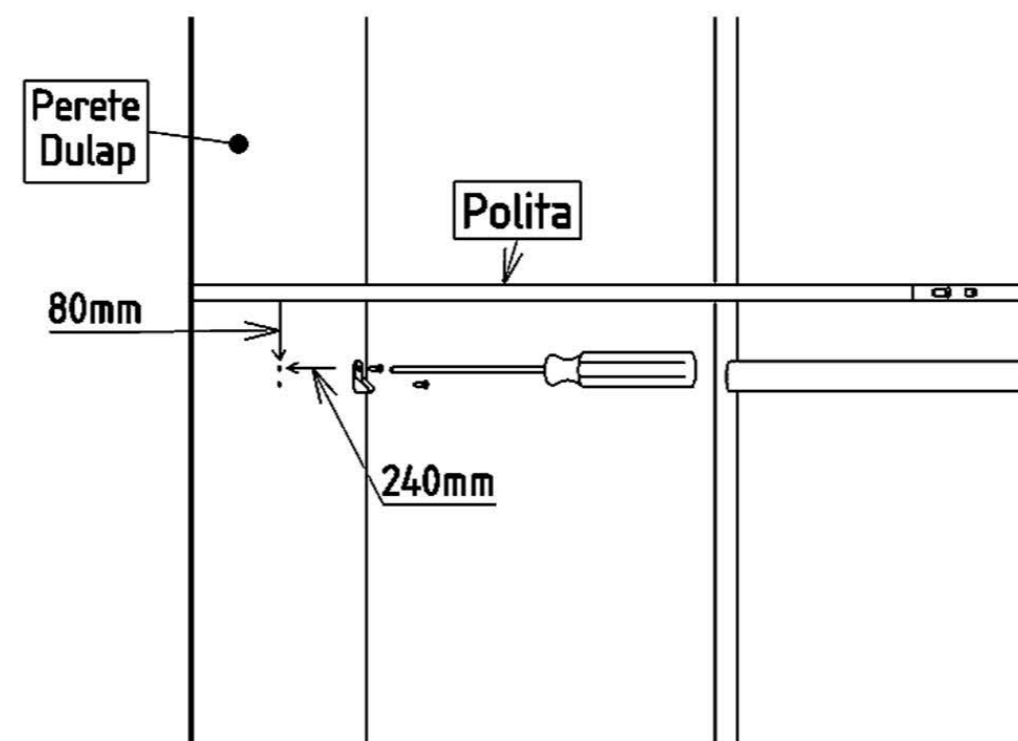
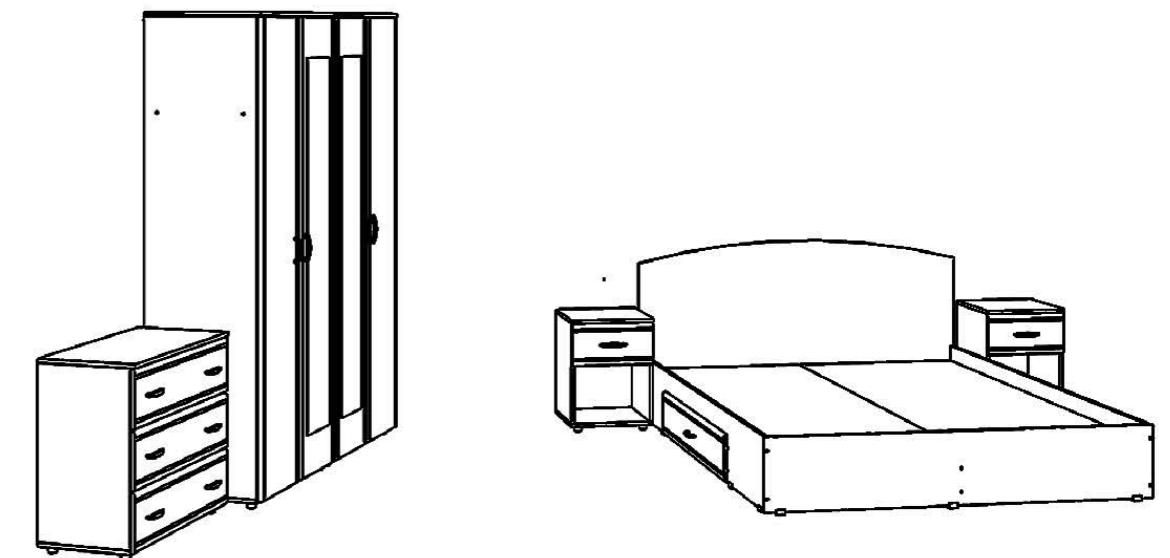
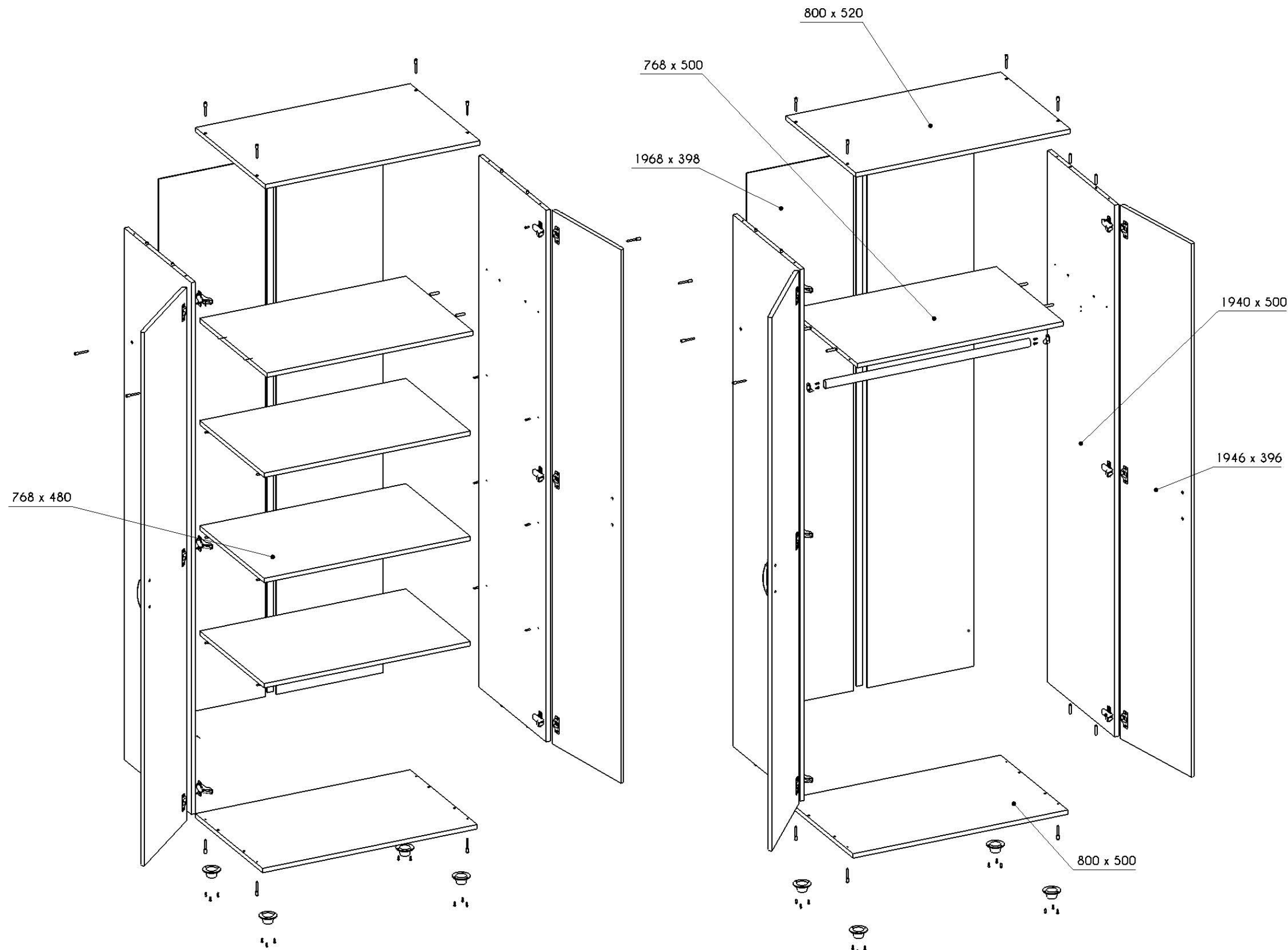

Fig. 5



Dormitor VALY - Schita Montaj Dulap



- se bat cepurile din lemn in peretii laterali si polite cu un ciocan (Fig. 1)
- se aseaza peretele stanga cu partea cantuita in jos si se prinde polita fixa cu ericson (Fig. 2)
- se prinde cu ericsoane, peretele dreapta si cele 2 capace
- se masoara cele 2 diagonale (Fig 3) si se impinge in colturi pana sunt egale. Se prinde PFL-ul in tinte.
- se prind picioarele cu holzsuruburi de capacul de jos si se ridica dulapul in picioare
- se prind balamalele pe usi (pe usile din mijloc se prinde oglinda centrat, cu banda adeziva)
- se prind usile de corp (Fig 4)
- se aliniaza cele 2 dulap-uri si se prind unul de cellalt cu 6 holzsuruburi 3.5x25
- se prind suportii pentru bara haine (Fig 5), se pune bara.
- se bat suportii pentru polita (metalici) in pereti si se aseaza politele mobile.
- se bat suportii pentru polita (metalici) in pereti si se aseaza politele

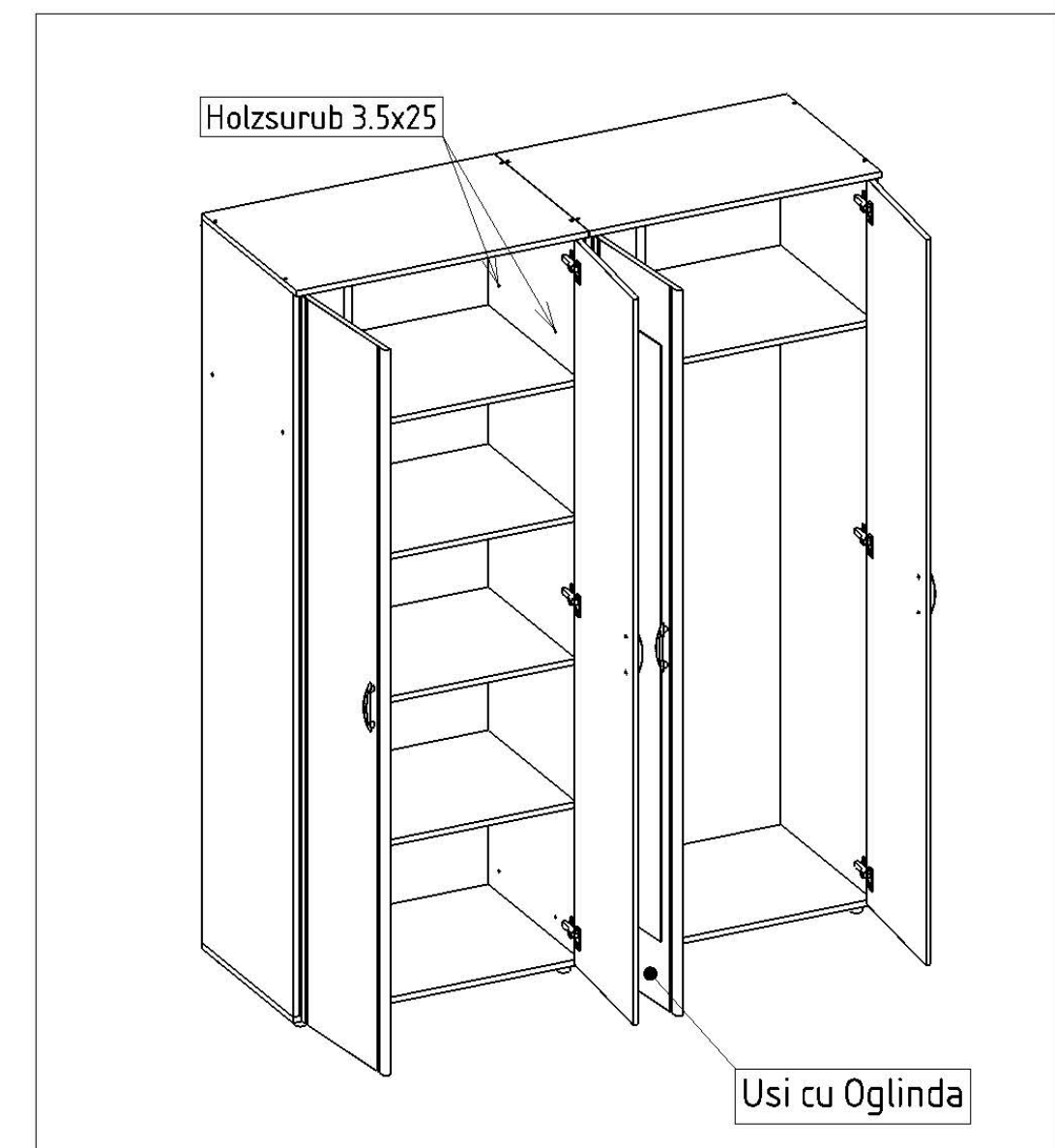

Dormitor VALY - Schita Montaj Dulap

- se prind picioarele cu Holzsuruburi 3.5x25 ca in schita. Intermediarele de la pat au cate 2 picioare (fiecare placa in parte), la distanta de 30mm fata de margine .
- se prind lezenele (210x80) cu Holzsuruburi 3.5x25 (ca in schita)
- se prind intermediarele cu ericsoane
- se prind cele 2 laterale cu ericsoane
- se prind cele 2 tablii
- se va monta sertarul in ericsoane, se masoara cele 2 diagonale si se prinde PFL-ul in tinte
- se prind cele 4 role cu Holzsuruburi 3.5x25 (centrat pe laterala sertarului)
- se prinde fata de sertrat cu cele 2 manere si suruburile 4x35
- se aseaza sertarul pe pozitie , se regleaza luftul, se trage afara si se va fixa cu 3 holzsuruburi 3.5x25 (fata de sertar, de cutie)

